

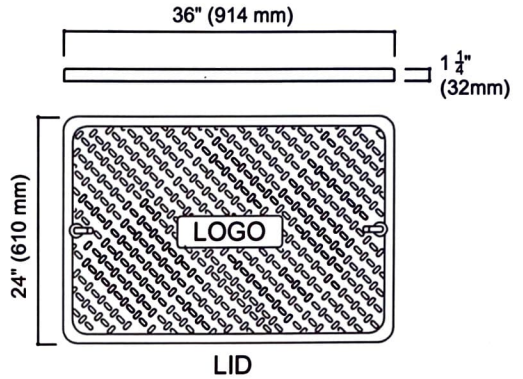

CIF
COMPOSITES INC.

ELECTRICAL Service box / Lid Assemble

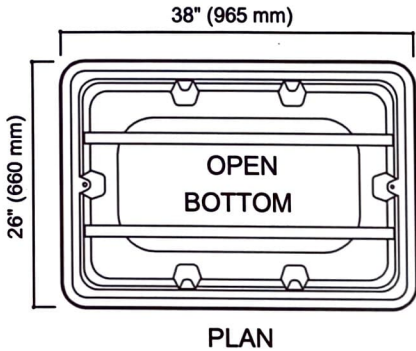

IMPORTANT
This design and drawing
is the property of
CIF COMPOSITES INC.
it is distributed for
reference purposes only.

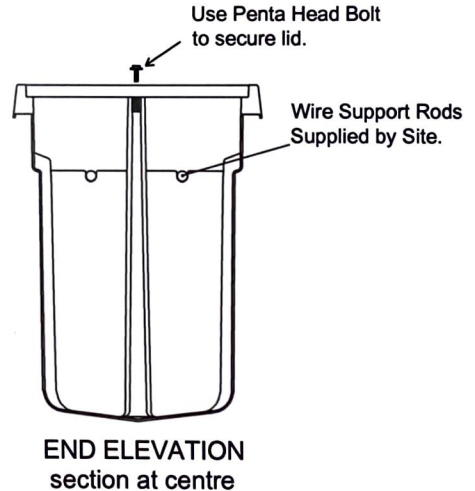
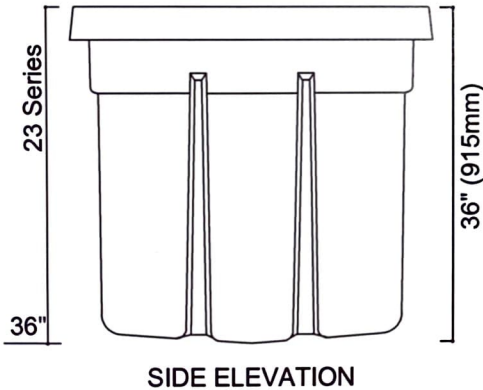

CODE: 2336 PLL - AE

PRO-ECO-LITE™

Revision Date: Jan. 2020

SCALE: N.T.S.

DRAWN BY: C.I.F. COMPOSITES (Jack K.)

HARDWARE: Penta head bolts c/w s.s. washers.

Lid Weight: 70 LBS. Box Weight: 58 lbs.

MATERIAL: Fiberglass c/w Polymer Concrete Core

LOAD RATINGS / NOTES:

- Actual load rating determined by box and lid combination.
- Service box designed for boulevard use.
- Backfill with coarse sand / tamping responsibility of others.